

# Temposonics®

Magnetostrictive, Absolute, Non-contact  
Linear-Position Sensors



## E-Series Model EH Synchronous Serial Interface (SSI) Output Data Sheet

Document Part Number:  
551314 Revision B



**Model EH rod-style position sensor**  
Stroke Length: 50 mm to 2500 mm (or 2 in. to 100 in.)

### FEATURES

- Linear, Absolute Measurement
- Non-Contact Sensing Technology
- Linearity Deviation Less Than 0.02% F.S.
- Repeatability Within 0.005% F.S.
- SSI Provides a High-Speed Noise Immune and Cost Effective Sensor interface
- Stroke Length Range: 50 mm to 2500 mm (or 2 in. to 100 in.)
- Hermetically-Sealed Stainless Steel For IP69K Ingress Protection
- EMI Shielded and CE Certified

### BENEFITS

- Compact Stainless Steel Position Sensor, Designed For Use In Hydraulic Cylinders
  - Standard 10 mm dia. Sensor Rod For Typical Applications
  - Optional 7 mm dia. Sensor Rod For Use In Small Bore Cylinders
- Resolution Down to 20  $\mu\text{m}$
- Direct 24/25 Bit SSI Output, Gray/Binary Formats
- Over Voltage Protection to 36 Vdc and Polarity Protection up to -30 Vdc

### APPLICATIONS

- Clevis Mounted or Space Limited Cylinder Applications
- Harsh Industrial Conditions
- High-Pressure Washdown
- Gates and Valve Control

### TYPICAL INDUSTRIES

- Fluid Power
- Factory Automation
- Steel Mills
- Material Handling and Packaging
- Water Management

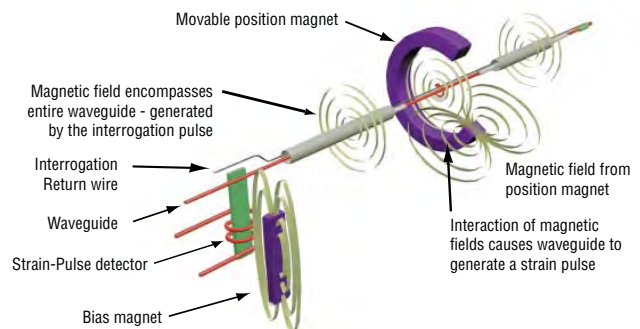

### Benefits of Magnetostriction

Temposonics linear-position sensors use the time-based magnetostrictive position sensing principle developed by MTS. Within the sensing element, a sonic-strain pulse is induced in a specially designed magnetostrictive waveguide by the momentary interaction of two magnetic fields. One field comes from a movable permanent magnet that passes along the outside of the sensor. The other field comes from an “interrogation” current pulse applied along the waveguide. The resulting strain pulse travels at sonic speed along the waveguide and is detected at the head of the sensing element.

The position of the magnet is determined with high precision and speed by accurately measuring the elapsed time between the application of the interrogation pulse and the arrival of the resulting strain pulse with a high-speed counter. The elapsed time measurement is directly proportional to the position of the permanent magnet and is an absolute value. Therefore, the sensor's output signal corresponds to absolute position, instead of incremental, and never requires recalibration or re-homing after a power loss. Absolute, non-contact sensing eliminates wear, and guarantees the best durability and output repeatability.

Sold & Serviced By:



Toll Free Phone (877) SERV098  
Toll Free Fax (877) SERV099  
[www.electromate.com](http://www.electromate.com)  
[sales@electromate.com](mailto:sales@electromate.com)

## E-Series Model EH Sensor, SSI Output

### Product Overview/Specifications

#### Product overview

MTS Sensors continues to establish new performance standards for low-cost, fully-industrial, durable position sensors using the widely preferred magnetostrictive technology. This principle for accurate and non-contact measurement of linear-position sensing was developed 30 years ago by MTS and is used with outstanding success in a large variety of industrial applications. The Temposonics model EH sensor provides as much performance as you need for your application - you benefit from the advantages of magnetostrictive position measurement at optimum costs.

The Temposonics® Model EH sensor features a pressure resistant sensor rod for direct stroke measurement inside hydraulic cylinders. With its minimized sensor head and either a 7 mm or 10 mm rod, it is the ideal solution when space is critical. For long strokes, the model EH is available with measuring ranges up to 2500 mm (or 100 in.).

The model EH sensor offers completely sealed stainless-steel housing for long life position measurement for rugged environments. When installed with the appropriate mating connector and cable, it features protection up to IP69K and is suitable for high-pressure washdown applications.

#### Product specifications

Parameters	Specifications
<b>OUTPUT</b>	
<b>Measured output variable:</b>	Position
<b>Resolution:</b>	20 µm, 50 µm, 100 µm
<b>Update rate:</b>	
<b>Measuring length:</b>	300 mm    750 mm    1000 mm    2000 mm
<b>Measurements/Sec.:</b>	3.7 kHz    3.0 kHz    2.3 kHz    1.2 kHz
<b>Linearity deviation:</b>	< ± 0.02% full stroke (minimum ± 60 µm)
<b>Repeatability:</b>	< ± 0.005% full stroke (minimum ± 20 µm)
<b>Outputs:</b>	<b>Interface:</b> Synchronous Serial Interface (SSI). (RS-422 type differential signal pairs)  <b>Data format:</b> Binary or gray <b>Data length:</b> 24 or 25 bit <b>Data speed (Baud rate):</b> 70 kBd to 1 MBd, depending on cable length (see below)
<b>Length (m):</b>	<3    <50    <100    <200    <400
<b>Baud rate:</b>	1.0 MBd    <400 kBd    <300 kBd    <200 kBd    <100 kBd
<b>Stroke length:</b>	<b>Range:</b> 50 mm to 2500 mm (or 2 to 100 in.)
<b>ELECTRONICS</b>	
<b>Operating voltage:</b>	<b>+24 Vdc nominal:</b> -15% or +20% <b>Polarity protection:</b> ≥ -30 Vdc <b>Over voltage protection:</b> ≤ 36 Vdc <b>Current drain:</b> 90 mA typical  <b>Dielectric withstand voltage:</b> 500 Vdc (DC ground to machine ground)

Parameters	Specifications
<b>ENVIRONMENTAL</b>	
<b>Operating conditions:</b>	<b>Operating temperature:</b> -40 °C (-40 °F) to 75 °C (167 °F) <b>Relative humidity:</b> 90% no condensation <b>Ingress protection:</b> IP69K (when appropriate mating connector is correctly fitted)
<b>EMC test:</b>	<b>Electromagnetic emission:</b> EN 61000-6-3 <b>Electromagnetic immunity:</b> EN 61000-6-2 The sensor meets the requirements of the EC directives and is marked with CE
<b>Shock rating:</b>	100 g (single hit)/ IEC standard EN 60068-2-27
<b>Vibration rating:</b>	15 g/10 to 2000 Hz, IEC standard EN 60068-2-6 (resonance frequencies causing excess of 15 g are excluded)
<b>WIRING</b>	
<b>Connection type:</b>	8-pin (M12) male integral connector
<b>ROD-STYLE SENSOR (MODEL EH)</b>	
<b>Electronic head:</b>	Stainless Steel 1.4301 / AISI 304
<b>Sensor rod:</b>	Stainless Steel 1.4301 / AISI 304
<b>Operating pressure:</b>	<b>7 mm Rod:</b> 300 bar static, 350 bar peak (4350 psi static, 5076 psi peak) <b>10 mm Rod:</b> 350 bar static, 450 bar peak (5076 psi static, 6526 psi peak)
<b>Mounting:</b>	Any orientation. Threaded flange M18 x 1.5 or 3/4 - 16 UNF-3A
<b>Typical mounting torque:</b>	45 N-m (33 ft. - lbs.)
<b>Magnet types:</b>	Ring magnet, open-ring magnet or magnet float

Sold & Serviced By:

 **ELECTROMATE**

Toll Free Phone (877) SERV098

Toll Free Fax (877) SERV099

www.electromate.com

sales@electromate.com

## Synchronous Serial Interface (SSI)

Temposonics E-Series sensors with SSI fulfill all requirements of the SSI standard for an absolute encoder. The position value is encoded in a 24/25 code format and is transmitted at high speed in SSI standard format to the control device. The main feature of SSI is the synchronized data transfer. Data transfer synchronization simplifies the closed-loop control system. A clock pulse train from a controller is used to gate out sensor data. One bit of position data is transmitted to the controller for each clock pulse received by the sensor (see 'Figures 1 and 2'). The absolute position data is continually updated by the sensor and converted by the shift register into serial information. (see 'Figure 3').

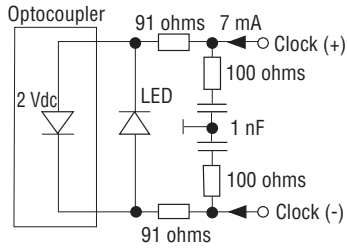

Figure 1. Sensor input

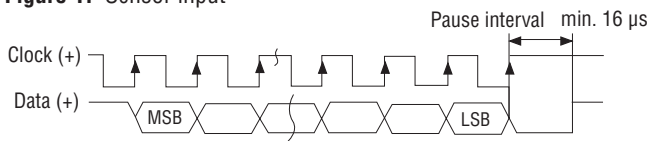

Figure 2. Timing Diagram

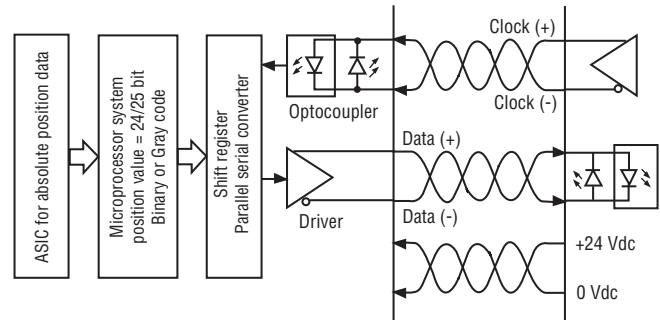

Figure 3. Logic Diagram

## Sensor dimension references

Drawings are for reference only, contact applications engineering for tolerance specific information.

The model EH sensor shown in 'Figure 4' can be ordered with flange styles M18 x1.5 or 3/4 -16 UNF-3A and a 7 mm or 10 mm diameter sensor rod. Magnets must be purchased separately; refer to 'Standard magnet Selections (Model EH)' for standard magnet ordering information.

### MODEL EH

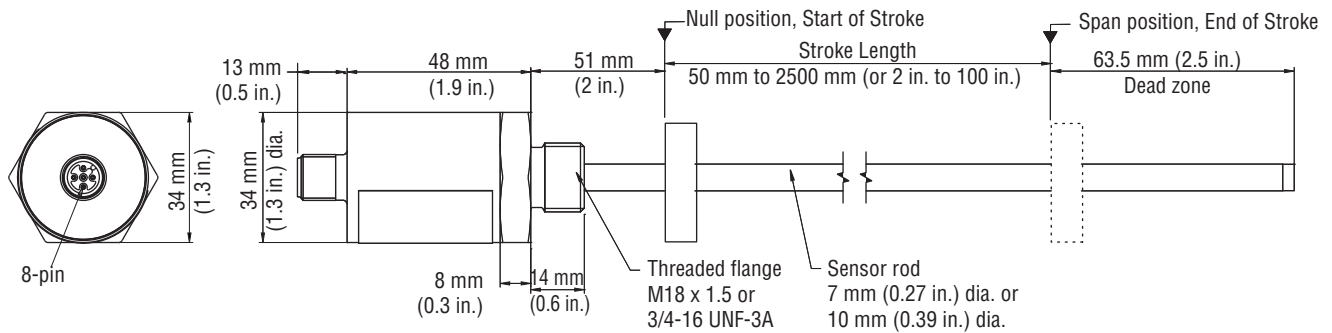

Refer to the model EH sensor ordering information for rod housing and flange types

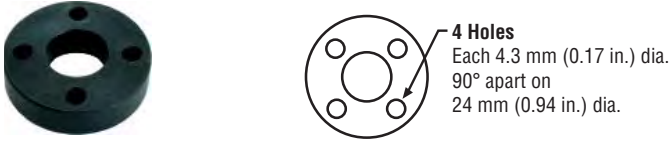
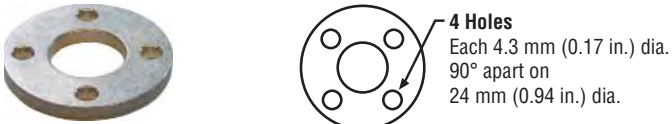

Figure 4. E-Series model EH sensor dimension reference

**E-Series Model EH Sensor, SSI Output**  
**Standard Magnet Selections**

**Standard magnet options (Model EH)**

Magnets must be ordered separately with Model RH position sensors. The standard ring magnet (part number 201542-2) is suitable for most applications.

**POSITION MAGNET SELECTIONS (Magnet must be ordered separately)** *(Drawing dimensions are for reference only)*

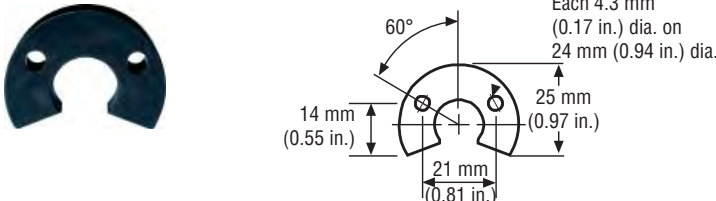
Magnet and magnet dimensions	Description	Part number
	<p><b>Standard ring magnet</b>  <b>I.D.:</b> 13.5 mm (0.53 in.)  <b>O.D.:</b> 33 mm (1.3 in.)  <b>Thickness:</b> 8 mm (0.3 in.)  <b>Operating temperature:</b>                      - 40 °C to 100 °C</p>	201542-2
	<p><b>Magnet spacer</b>                      (Non-ferrous, use with ring magnet                      Part number: 201542-2)  <b>I.D.:</b> 14 mm (0.56 in.)  <b>O.D.:</b> 32 mm (1.25 in.)  <b>Thickness:</b> 3.2 mm (0.125 in.)</p>	400633
	<p><b>Ring magnet</b>  <b>I.D.:</b> 13.5 mm (0.53 in.)  <b>O.D.:</b> 25.4 mm (1 in.)  <b>Thickness:</b> 8 mm (0.3 in.)  <b>Operating temperature:</b>                      - 40 °C to 100 °C</p>	400533
	<p><b>Open-ring magnet, Style M</b>  <b>I.D.:</b> 13.5 mm (0.53 in.)  <b>O.D.:</b> 33 mm (1.3 in.)  <b>Thickness:</b> 8 mm (0.3 in.)  <b>Operating temperature:</b>                      - 40 °C to 100 °C</p> <p>This magnet may influence the sensor performance specifications for some applications.</p>	251416-2

**MAGNET FLOAT SELECTION** *(Drawing dimensions are for reference only)*

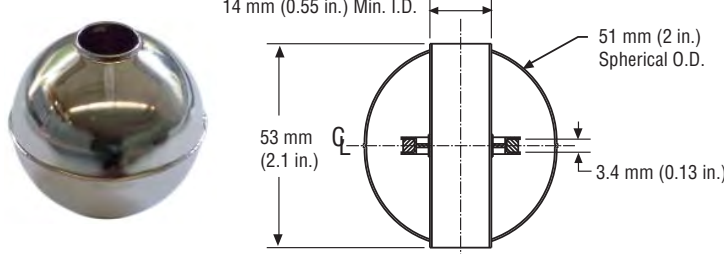
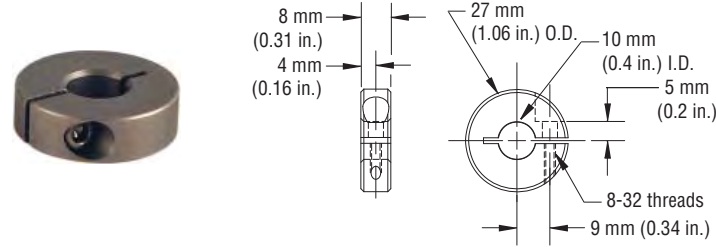
	<p><b>Magnet float</b>                      (Level sensing applications)  <b>Specific gravity:</b> 0.70 maximum  <b>Pressure:</b> 870 psi maximum</p> <p>(This float is used with Model RH rod-style sensors for hydraulic fluid or fresh water applications only). Collar (part no.: 560777) is recommended for end of stroke stops.</p>	251447
	<p><b>Collar</b>                      Provides end of stroke stops for magnet float (part no.: 251447)</p>	560777

Sold & Serviced By:



Toll Free Phone (877) SERV098  
 Toll Free Fax (877) SERV099  
[www.electromate.com](http://www.electromate.com)  
[sales@electromate.com](mailto:sales@electromate.com)

## Model EH Rod-Style sensor mounting

### MODEL EH SENSOR MOUNTING

The model EH sensor is designed for direct stroke measurement inside prepared hydraulic cylinders. At the head of the sensor, a threaded flange and O-Ring provides for mounting and sealing the sensor into a port opening in the cylinder end cap. The sensor's pressure resistant rod fits into a bore drilled through the center of the piston head and rod assembly. The sensor's position magnet is mounted on the top of the piston head or installed in a shallow counter-bore inside the piston head.

The position magnet requires minimum distances away from ferrous metals to allow proper sensor output. The minimum distance from the front of the magnet to the cylinder end cap is 15 mm (0.6 in.).

The minimum distance from the back of the magnet to the piston head is 3.2 mm (0.125 in.). However, a minimum distance of at least 5 mm (0.197 in.) is preferred for performance margin. The non-ferrous spacer (part no. 400633), provides this minimum distance when used along with the standard ring magnet (part no. 201542-2), as shown in 'Figure 5'.

The magnet is usually secured using non-ferrous fastening material (customer supplied). Screws must be made of nonmagnetic stainless steel or brass. In the event that a ferrous circlip or retaining ring will be used to secure the magnet in a counter-bore then an additional non-ferrous spacer (> or = 3.2 mm) must be placed between the circlip or retaining ring and the front side of the magnet.

The cylinder's design ratings for hydraulic pressure and piston velocity will determine the appropriate size for the bore that is drilled through the center of the piston head and rod assembly. The recommended minimum size for this bore is 10 mm (0.39 in.) when using the 7 mm (0.27 in.) diameter sensor rod.

Likewise, the recommended minimum size of 13 mm (0.51 in.) should be used when installing the 10 mm diameter sensor rod. Some applications using long sensor rods may benefit by adding a bushing (e.g. made of flourelastomer material) to prevent wear on the magnet and sensor rod (customer supplied).

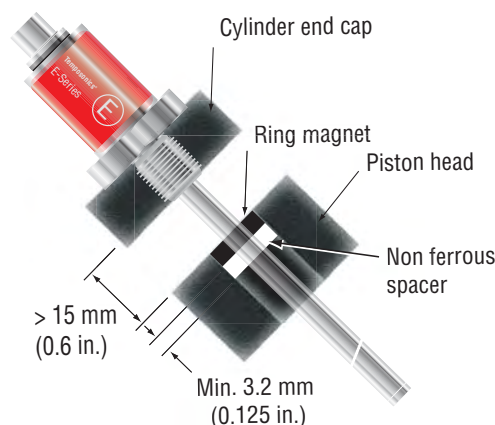

**Figure 5.** Model EH rod-style mounting

## Connections and wiring (Model EH)

### SENSOR INTEGRAL CONNECTOR (D84) PINOUT/WIRE COLOR CODES

The E-Series Model EH sensor connects directly to a controller or interface module with the standard male, 8-pin integral connector and an extension cable as described in 'Table 1'



**Integral D84 connector (male) as viewed from the end of the sensor**

Pin no.	Extension cable wire color	Signal/function Start/Stop outputs
1	White	Clock (+)
2	Brown	Clock (-)
3	Green	Data (+)
4	Yellow	Data (-)
5	Gray	No connection
6	Pink	No connection
7	Blue	+24 Vdc
8	Red	DC ground (for power return)

**Table 1.** Integral D84 sensor connector

**E-Series Model EH Sensor, SSI Output**  
**Mounting Reference, Connections and Wiring**

**MATING CABLE CONNECTOR OPTIONS FOR (D84) CONNECTOR TYPES** *(Photo and drawing dimensions are for reference only)*

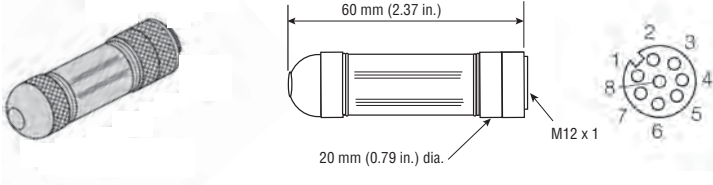
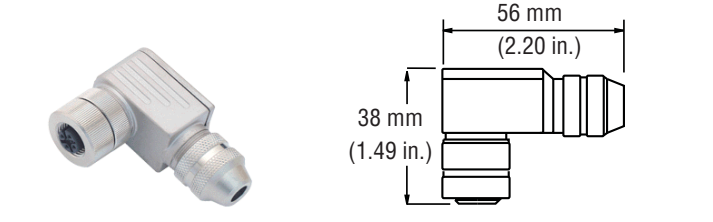
Connector and dimensions	Description	Part number
	<p><b>Female cable connector, straight exit (Field installable)</b>            8-Pin (D84)            Mates with standard male (M12) integral connector  <b>Termination:</b> Screw terminals  <b>Cable gland:</b> PG9 for 6-8 mm dia. cable  <b>Ingress protection:</b> IP67</p>	370694
	<p><b>Female cable connector, 90° exit (Field installable)</b>            8-Pin (D84)            Mates with standard male (M12) integral connector  <b>Termination:</b> Screw terminals  <b>Cable gland:</b> PG9 for 6-8 mm dia. cable  <b>Ingress protection:</b> IP67</p>	370699

**M12 CORD SETS** *(Photo and drawing dimensions are for reference only)*

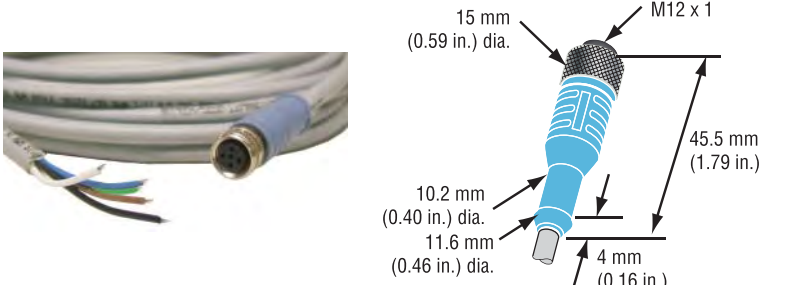
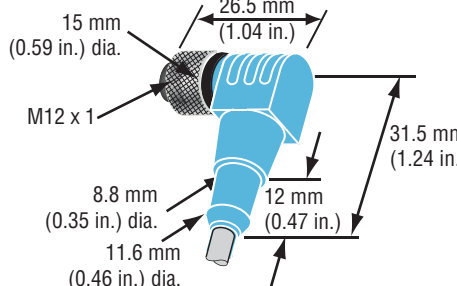
	<p><b>M12 Cord set, female connector, straight exit</b>            8-Pin (M12) mates with standard male (D84) integral connector  <b>Ingress protection:</b> IP67  <b>Cable:</b> 5 m, shielded, pigtail end</p>	370674
<p><i>(Image not available)</i></p> 	<p><b>M12 Cord set, Female, Connector 90° Exit</b>            8-Pin (M12) mates with standard male (D84) integral connector  <b>Ingress protection:</b> IP67  <b>Cable:</b> 5 m, shielded, pigtail end</p>	370676

Sold & Serviced By:



Toll Free Phone (877) SERV098

Toll Free Fax (877) SERV099

www.electromate.com

sales@electromate.com

## E-Series Model EH Sensor, SSI Output Ordering Information

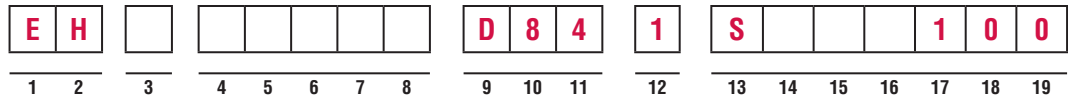

(Use the order matrix above to configure your Model EH sensor order number)

- SENSOR MODEL** \_\_\_\_\_ = E H 1 - 2
- EH** = E-Series model EH rod-style sensor (Magnet(s) must be ordered separately)
- ROD HOUSING AND FLANGE TYPE** \_\_\_\_\_ =  3
- K** = Flange M18 x 1.5 / Rod 7 mm dia.  
**M** = Flange M18 x 1.5 / Rod 10 mm dia.  
**L** = Flange 3/4 in. UNF / Rod 7 mm dia.  
**S** = Flange 3/4 in. UNF / Rod 10 mm dia.
- STROKE LENGTH** \_\_\_\_\_ =  4 - 8
- **M** = Millimeters (Encode in 5, 10, 25 or 50 mm increments) as indicated in 'Stroke length notes' below.  
 ----- **U** = Inches (Encode in 0.2, 0.5, 1 or 2 in. increments) as indicated in 'Stroke length notes' below.

Stroke Length Notes:	
<b>Stroke length ranges:</b>	
<b>M</b> = 50 mm to 2500 mm	
<b>U</b> = 2 in. to 100 in.	
<b>The increment size between standard stroke lengths vary as shown below:</b>	
Stroke length (mm)	Ordering increment
< 500 mm	5 mm
> 500 mm and ≤ 750 mm	10 mm
> 750 mm and ≤ 1000 mm	25 mm
> 1000 mm and ≤ 2500 mm	50 mm
Stroke length (IN)	Ordering increment
≤ 20 in.	0.2 in.
> 20 in. and ≤ 30 in.	0.5 in.
> 30 in. and ≤ 40 in.	1 in.
> 40 in. and ≤ 100 in.	2 in.

- SENSOR CONNECTION TYPES** \_\_\_\_\_ = D 8 4 9 - 11
- D84** = 8-Pin (M12), male, (SSI output)
- INPUT VOLTAGE** \_\_\_\_\_ = 1 12
- 1** = + 24 Vdc (+20%, -15%), standard
- OUTPUT** \_\_\_\_\_ = S   1 0 0 13-19
- S** ----- = SSI output - Enter the 6-digit output code (1-6) defined by the selections below:
- [1] [2] [3] [4] [5] [6]

- |   |  |   |  |
|---|--|---|--|
| <b>[14] Data length</b><br><b>1</b> = 25 bits<br><b>2</b> = 24 bits | <b>[15] Output format</b><br><b>B</b> = Binary<br><b>G</b> = Gray code | <b>[16] Resolution</b><br><b>3</b> = 0.05 mm<br><b>4</b> = 0.1 mm<br><b>5</b> = 0.02 mm | <b>[17] Performance</b><br><b>1</b> = Standard |
|---|--|---|--|

- [18] [19] Signal options (scale orientation)**  
**00** = Measuring direction forward, async